

AMENDMENTS TABLE (PLAN GRAPHICS ONLY)

VER.	AMENDMENT	AUTHORISED BY	DATE
2	RE-LODGE OF EXPIRED PLAN	M. SPINELLI	24/02/21
3	DFM NOTATIONS ADDED	M. SPINELLI	12/03/21

TYPE FREEHOLD S.S.A. YES/NO

PURPOSE SUBDIVISION

PLAN OF
LOTS 3, 8-11 & ROAD WIDENING

FORMER TENURE LOT 9002 ON DP 413954 C/T 2960-323

LOCAL AUTHORITY SHIRE OF DENMARK

LOCALITY HAY

D.O.L. FILE

FIELD RECORD 141762

SURVEYOR'S CERTIFICATE - REG 54
I, M. SPINELLI
hereby certify that this plan is accurate and is a correct representation of the -
(a) *survey; and/or
(b) *calculations from measurements recorded in the field records,
[* delete if inapplicable]
undertaken for the purposes of this plan and that it complies with the relevant written law(s) in relation to which it is lodged.
M. Spinelli 2021.03.12 10:41:03 +08'00'
LICENSED SURVEYOR DATE

LOGGED
7.11.2018
DATE FEE PAID ASSESS No.

I.S.C.
EXAMINED
E. Milewska 15.03.2021 DATE

WESTERN AUSTRALIAN PLANNING COMMISSION
FILE 155620
C. Gustavsson
30-Mar-2021
Delegated under S.16 P&D Act 2005 DATE

IN ORDER FOR DEALINGS
SUBJECT TO
SEC 168(3), 165 OF THE P&D ACT
SEC 70A OF THE TLA

R. W.
INSPECTOR OF PLANS AND SURVEYS DATE

APPROVED Reg 26A(1),(4)
INSPECTOR OF PLANS AND SURVEYS DATE
(S. 18 Licensed Surveyors Act 1909)



DEPOSITED PLAN
413974
SHEET 1 OF 1 SHEETS
(PLUS SURVEY SHEET(S))
VERSION 3

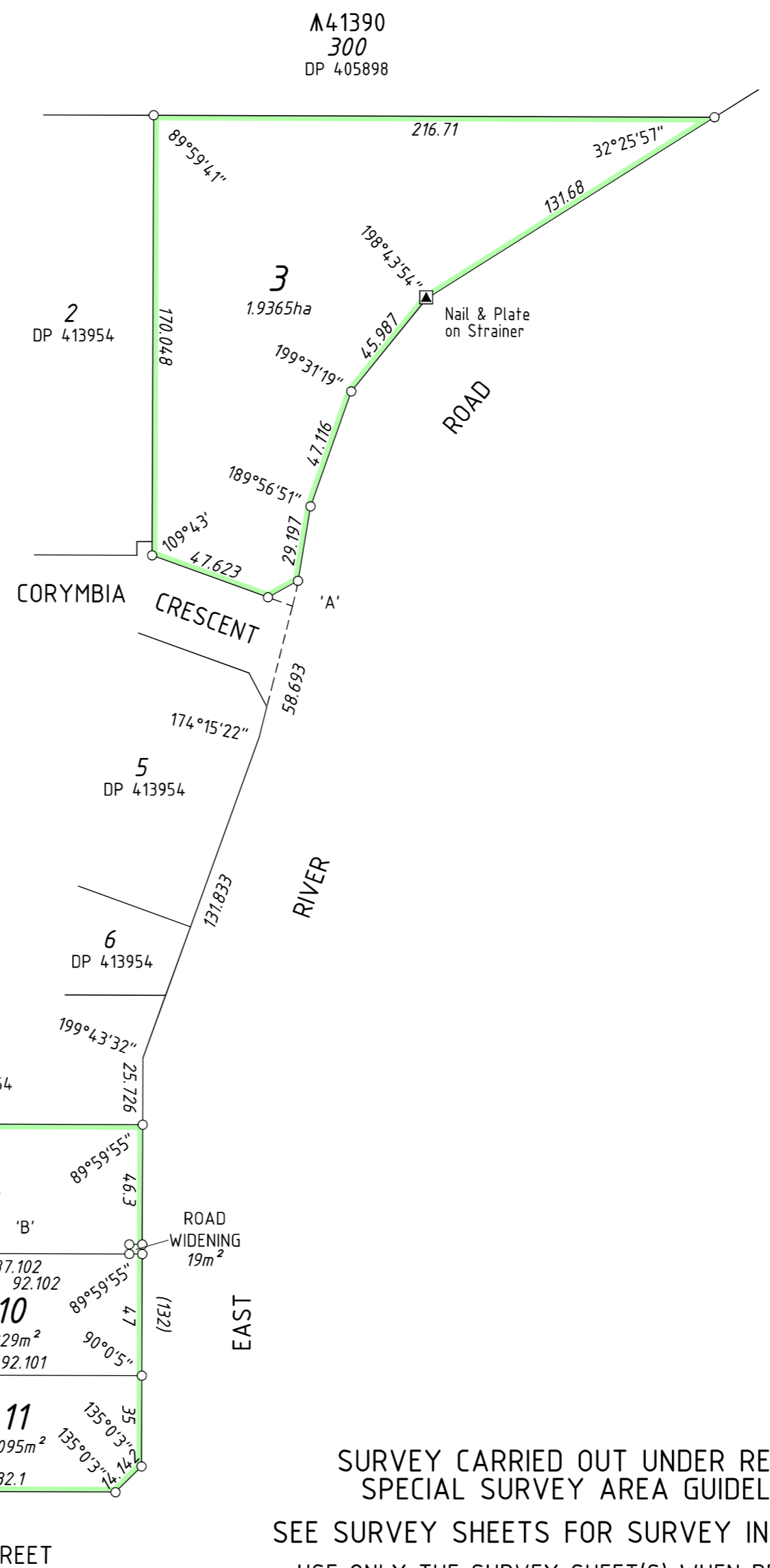
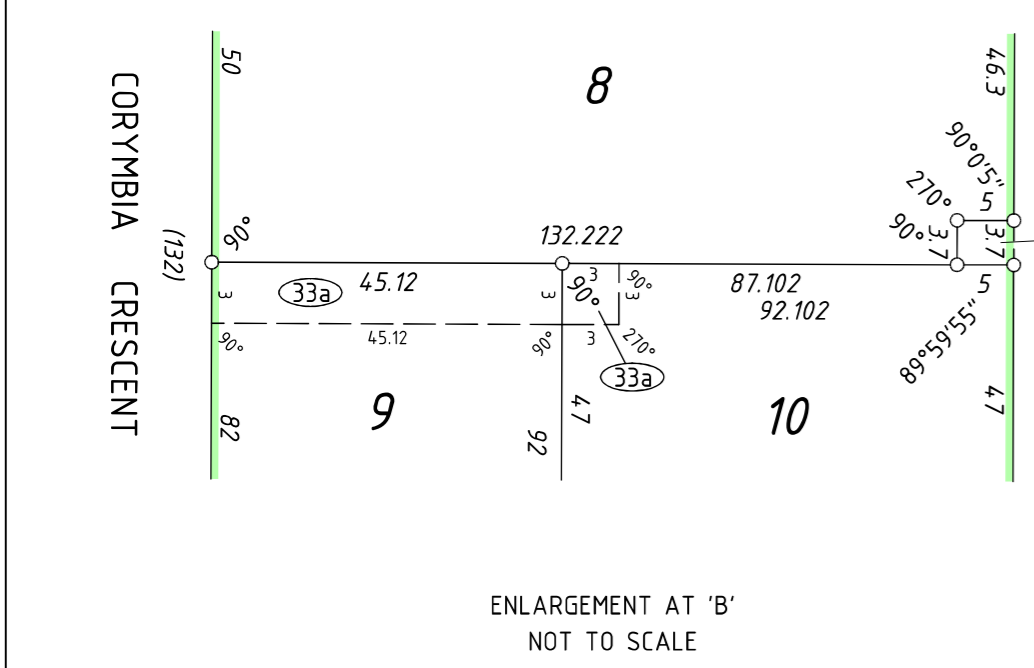
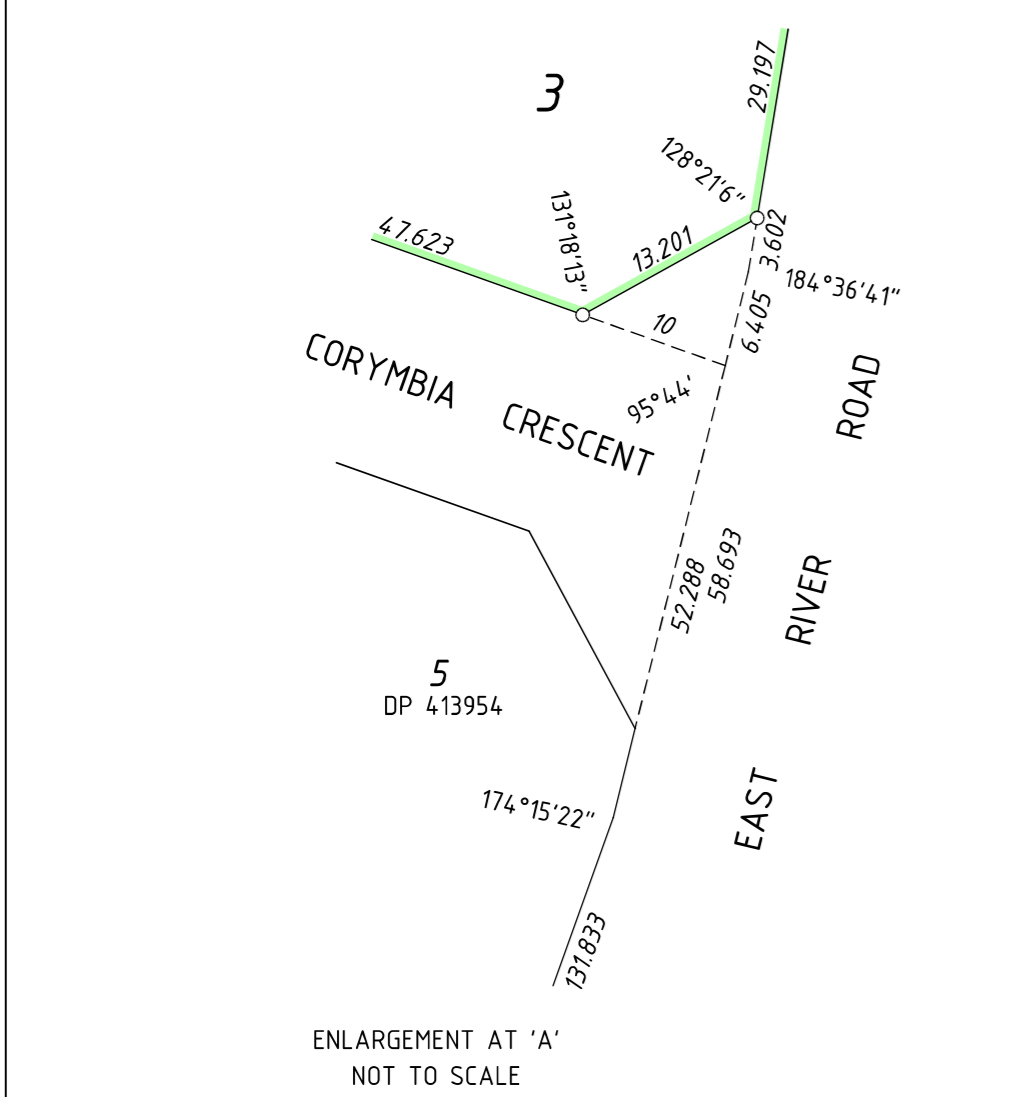

SURVEY CARRIED OUT UNDER REG 26A
SPECIAL SURVEY AREA GUIDELINES
SEE SURVEY SHEETS FOR SURVEY INFORMATION
USE ONLY THE SURVEY SHEET(S) WHEN DETERMINING
THE TRUE FINAL POSITION AND TYPE OF ALL SURVEY
MARKS PLACED PERTAINING TO THIS PLAN

REG 26A(1) - FINAL MARKING DEFERRED
(APPROVAL ID D074-18; LANDGATE FILE 05337-2017)

INTERESTS AND NOTIFICATIONS						
SUBJECT	PURPOSE	STATUTORY REFERENCE	ORIGIN	LAND BURDENED	BENEFIT TO	COMMENTS
33a	EASEMENT (DRAINAGE)	SEC 167 OF THE P & D ACT REG 33(a)	DP 413954	LOTS 9 & 10	SHIRE OF DENMARK	
	NOTIFICATION	SEC 70A OF THE TLA	DOC	LOTS 3, 8-11		WAPC (Adjacent nature reserve)
	NOTIFICATION	SEC 70A OF THE TLA	DOC	LOTS 3, 8-11		SHIRE OF DENMARK (Reticulated sewer unavailable)
	NOTIFICATION	SEC 70A OF THE TLA	DOC	LOTS 3, 8-11		WATER CORPORATION (Water pressure)
	NOTIFICATION	SEC 165 OF THE P & D ACT	DOC	LOTS 3, 8-11		BUSHFIRE PRONE AREA & ATU REQUIRED FOR EFFLUENT DISPOSAL

HD Ref 20602L1-05C BdR 23/02/21

SCALE 1:2000 @ A2
0 20 40 60 80 100
ALL DISTANCES ARE IN METRES



31 Albany Highway, ALBANY
T: 08 9844 5100
W: www.harleydykstra.com.au
E: Drafting@harleydykstra.com.au

